

HEWLETT-PACKARD JOURNAL

SPECTRUM USAGE

San Francisco, Calif.

08:22 AM - Dec 22, 1971

BAND	FREQ. RANGE	STATUS	OPERATOR ACTION
LAND MOBILE	25-70 MHz 158-159 MHz 458-478 MHz	7% OCCUPANCY In available channels	(Point to Menu with Cursor/Track Ball)
VHF TV	54-72 MHz 76-88 MHz 174-216 MHz	CH 2,4,5,7,11 On the air	-----DISPLAY SINGLE BAND
FM BROADCAST	88-108 MHz	32 STATIONS On the Air 89.5-107.7 MHz	-----TUNE TO SINGLE FREQ.
AIR TRAFFIC CONTROL	119-136 MHz	UNAUTHORIZED SIGNAL at 126.188 MHz	-----RE-SCAN TOTAL SPECTRUM 25-306 MHz
UHF TV	512-566 MHz	CH 14,20,32,36 On the Air	

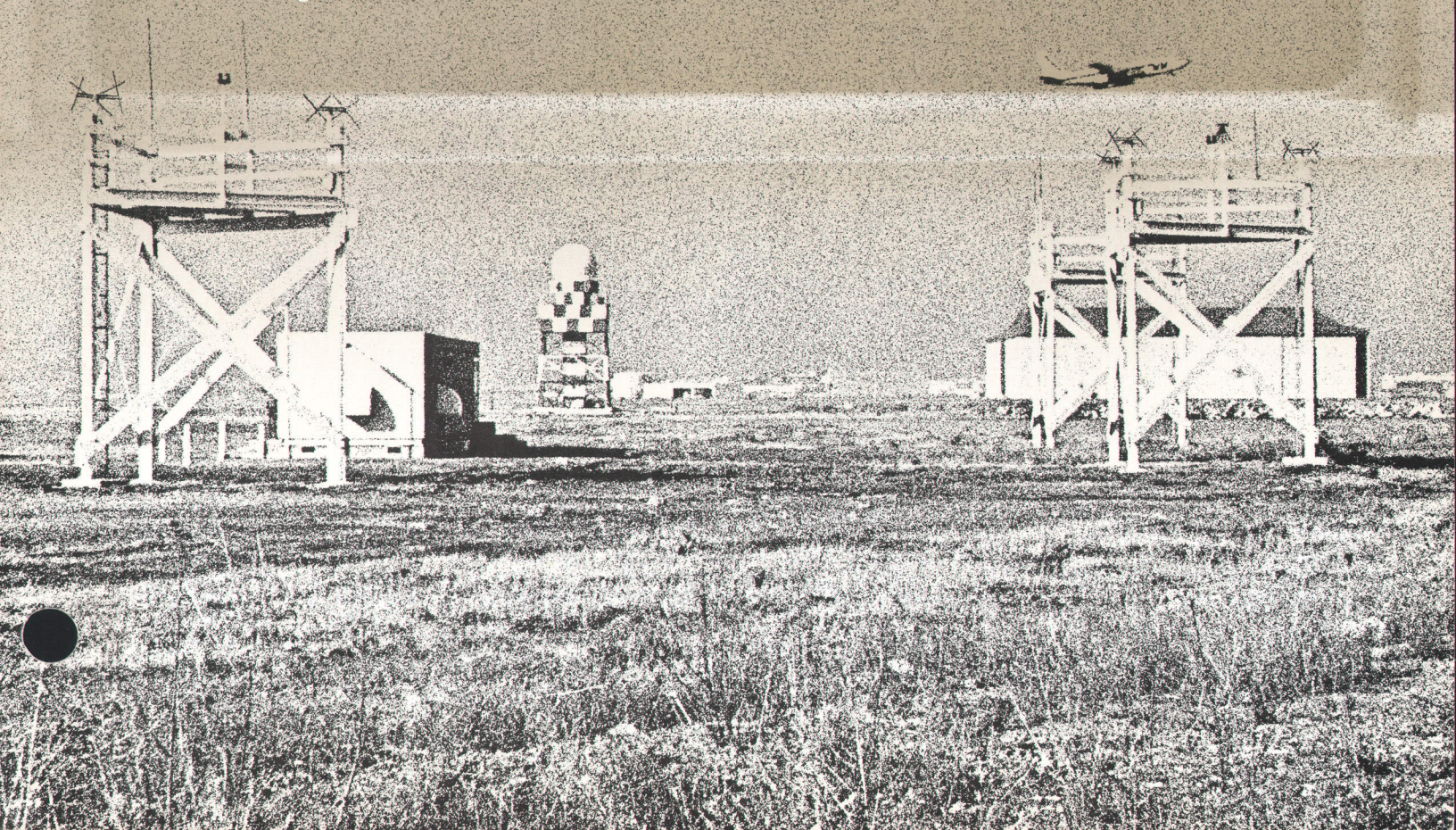

Introducing the Automatic Spectrum Analyzer

Under computer control a modern spectrum analyzer becomes an entirely new instrument.

By Michael Cunningham and Lynn Wheelwright

AN AUTOMATIC SPECTRUM ANALYZER (Fig. 1) places the spectrum analyzer under computer control. Computer control, from a functional point of view, idealizes the analyzer. The user gives it a command and the computer does all the 'knob twiddling' for him. This frees the user to concentrate on the solution of his measurement problem rather than on its execution. The computer makes unattended spectrum surveillance practical, and it simplifies the measurement process for black box testing (Fig. 2) so cost-effectiveness is improved in many production-line situations. It not only makes available a hard copy of measurements performed but also an *analysis* of these measurements. This may, for example, be an elaborate statistical analysis. One can now sort out the important data, analyze it, and display only relevant information.

The computer-controlled system can be automatically calibrated. Error tables may be stored during calibration, then used to remove systematic errors from measurements executed later. Not only is this an inexpensive way to increase system accuracy, it also leads to more effective optimization of the hardware. One can gain more, overall, by concentrating on repeatability in indirect measurements than by straining for direct accuracy.

The Automatic Spectrum Analyzer (Model 8580A) is built from familiar RF hardware^{1,2} that covers the frequency range from 10 kHz to 18 GHz. Digital control and computation are accomplished by a system console that includes a small stored-program computer. This console is available with interactive graphics capability, to be described more fully in a following issue of the Hewlett-Packard Journal. Operator communication is via a set of commands that address the various instruments and data processing equipment.

The system organization is described in more

detail in the article which follows. A block diagram appears on page 8. The system consists of an input control unit which also contains the input attenuator, two front ends with their local oscillators, and an IF section which houses the detector and bandwidth filters. A basic improvement in accuracy and resolution results from using a synthesized first local oscillator and stabilized following oscillators in the microwave front end. The computer controls several functions in each section, as well as the input/output equipment of the system.

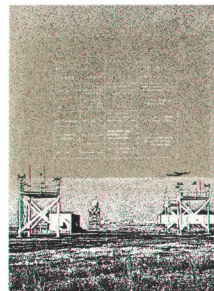

Cover: *Electromagnetic spectrum usage near any airport is awesome. This one is San Francisco International. New HP Automatic Spectrum Analyzer can detail the scene, identify alarm conditions, offer further options. Data simulated.*

In this Issue:

- Introducing the Automatic Spectrum Analyzer, by Michael Cunningham and Lynn Wheelwright* **page 2**
- Organizing the Automatic Spectrum Analyzer System, by William H. Shaffer* **page 7**
- Automating the 10-MHz-to-18-GHz Receiver, by Steven Neil Sanders* **page 10**
- Hewlett-Packard's Barney Oliver and John Cage Write The Book* **page 14**
- Fine-line Thermal Recording on Z-fold Paper, by Walter R. McGrath, Jr. and Arthur Miller* **page 17**



Fig. 1. Automatic Spectrum Analyzer (Model 8580A) can assume many configurations. This one is typical of those for use in automatic spectrum monitoring.

The input control unit also provides a power meter port, four signal-conditioning paths, and four output ports. Signal-conditioning might include pre-amps, filters, and mixers. Multiple output ports can route the selected input (under computer control) to other instruments. The power meter port precedes the attenuator for accuracy enhancement via self-calibration. Since input, signal-conditioning paths, and output are separately controlled, it becomes very simple to adapt the system for a particular measurement.

How Do You Use It?

To solve a measurement problem with the Automatic Spectrum Analyzer (ASA) the user first defines a procedure that puts the measurement system

in the desired condition (i.e., input port, tuning, IF bandwidth, sensitivity, etc.) to record absolute signal level at some given set of frequencies. The key element provided by the 8580A, beyond the basic capability of its RF hardware, is the command set, i.e., the system software, to implement the measurement procedure (Table 1).

The software is conversational, yet it allows the full capabilities of the hardware to be exploited. It handles such system idiosyncrasies as timing, errors, and data formatting for the instruments. It appears to the user as a set of mnemonic commands which control the four basic functional areas of the analyzer: calibration, initialization, tuning and measurement.

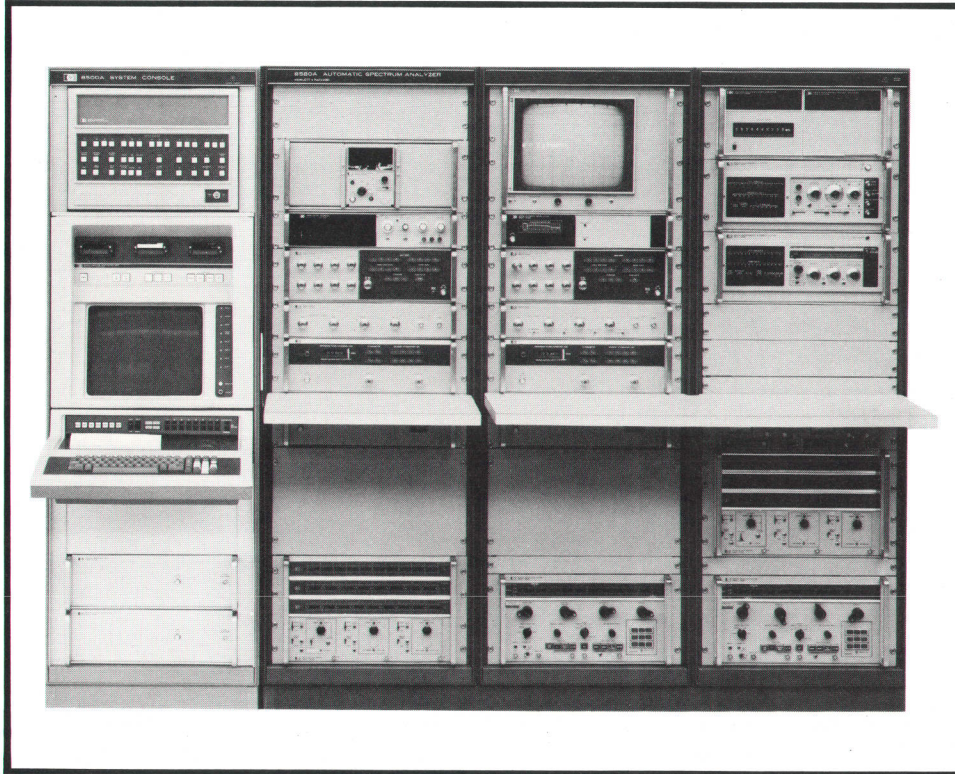

Fig. 2. Among important contributions of Automatic Spectrum Analyzer is addressing automatic systems to stimulus/response testing of nonlinear black box components. This one is configured especially for such uses.

Use of the command set can be illustrated by a simple example. Assume all radio transmitters in the FM broadcast band in a region are to be scanned and their received signal levels measured. To do this would simply involve a tune and measure loop as shown in Fig. 3. Following execution of the measurement loop, all data can be held in memory, displayed on the system CRT, or listed by the printer in tabular form.

These commands are usable with both an interpretive language, BASIC, and compiled language, FORTRAN. This combines the flexibility of online debugging with an interpreter, and the execution efficiency of a compiled language. The interpreter requires more memory and is slower in execution, but it allows the user to solve his measurement problems interactively, i.e., to edit his program at will. Compiled languages run faster and take less memory, but they are more cumbersome to use because any change in the program requires it to be re-compiled. New commands *can*, however, be added by the user to the basic set.

APPLICATIONS

The potential uses for the ASA fall naturally into two major classes. One can be called *spectrum monitoring*; it includes such end uses as site surveillance, system monitoring, electromagnetic compatibility testing (i.e., RFI tests), and some aspects

of electronic intelligence. The second class can be called *stimulus/response testing*; it includes the variety of frequency domain tests often run on such components as amplifiers, mixers, modulators, multipliers, oscillators, and combinations of these such as receivers or transmitters.

The Automatic Spectrum Monitor

Spectrum management has become a very important activity, as the demand increases for frequency allocations for communications, navigation, and other radio systems. The ASA, as a spectrum monitor, can run unattended to measure and compile actual spectrum utilization statistics over extended periods. A geographic region can be monitored, for example, to determine the frequencies and signal strengths of transient radio transmissions that may interfere with a proposed new receiver or transmitter site. A city might be monitored to determine the actual usage of shared radio channels before licensing additional users. At airports (cover photo), automatic spectrum monitoring can guarantee that key radio channels, needed for safe operation, are not accidentally jammed by an unexpected emitter. In all cases, automatic operation makes it economical to acquire the data necessary for informed, efficient spectrum management, and relieve the tedium of human observation.

One ASA system user extended the monitoring

Table I Automatic Spectrum Analyzer Command Set (Partial)	
Calibration	
CALLIB	Calibrates the analyzer using the built-in -30 dBm reference oscillator.
Initial Settings	
RESET (X,Y,Z)	Resets all instruments to a known state: Input select unit to port 1, Input attenuator to A = $X + 40$ dB $30 > X > -40$ = 0 dB $X < -40$ = 70 dB $X > 30$
IF Gain to 30 dB. Bandwidth to 300 kHz. Z selects the measurement correction algorithm, Y sets the system threshold level.	
ATTEN (A)	Sets the input attenuator: A = 0 to 70 dB in 10 dB steps.
GAIN (G)	Sets the IF gain: G = 0 to 50 dB in 10 dB steps.
BWIDTH (B)	Sets one of 10 IF bandwidths: 300, 100, 30, 10, 3, 1, 0.3, 0.1, 0.03, 0.1 kHz.
PORTS (I, J, K)	Selects the input port, signal conditioning path, and output port on the system input select unit.
Tuning	
TUNE (F)	Tunes the analyzer to the specified frequency: F is in MHz.
STEP (F)	Increments or decrements the frequency to which the analyzer is tuned: F is in kHz.
Measurement	
MEAS (S)	Measures the signal level at the detector, adds in the input attenuation, subtracts the IF gain, and reports in S the signal level at the input port.
PERI (F1, F2, F, R)	Searches the spectrum between F1 and F2 and reports the frequency and amplitude of the strongest signal.

		FREQ (MHz)	LEVEL (dBm)
5	REM	88.5	-65.8
	FM BAND OCCUPANCY PROGRAM	90.1	-69.3
		92.3	-47.6
		92.7	-78.9
10	RESET (-40, 100, 2)	93.3	-63.1
		94.1	-73.9
15	BWIDTH (10)	94.9	-57.2
		95.3	-75.3
20	PRINT "FREQ (MHz) LEVEL (dBm)"	95.7	-71.8
		96.5	-54.9
25	FOR I=1 TO 101	97.3	-61.7
		97.7	-64.8
30	TUNE (88.1+(I-1)*0.2)	98.1	-71.8
		99.7	-73.5
35	MEAS (A)	100.3	-61.6
		101.3	-61
40	IF A < -80 THEN 50	102.1	-72.3
		102.9	-76.3
45	PRINT 88.1+(I-1)*0.2, A	103.7	-76.2
		104.9	-57.5
50	NEXT I	105.3	-71.1
		105.7	-42.7
		106.1	-64.1
		106.5	-45.5
99	END	106.9	-67.9
		107.7	-45.2

Fig. 3. Tune and measure loop (left) produces printout (right) of all signals greater than -80 dBm.

ability of the system so far that it now controls a satellite communications network directly. Here numerous ground stations are accessing a satellite to relay their individual message channels over the horizon. In a typical network, the satellite is in geostationary orbit and has antenna coverage of thousands of square miles of the earth's surface. Hence, several ground stations can access the satellite at any time. These users must adhere to regulations that specify the signal power they deliver to the satellite to insure an equitable distribution of its available power. Many conditions, however, affect the signal level each station delivers to the satellite. Antenna orientation, atmospheric conditions and transmitter stability often cause the signal level received by the satellite to vary enough to result in unacceptable message quality. Some networks, moreover, authorize a given ground station to use the satellite only during specific predetermined periods. Typically, each ground station has a unique transmit frequency, so scanning the signals relayed by the satellite will identify any unauthorized user. The spectrum monitor is thus an important tool for on-line control of the satellite communication system.

For this control application, the ASA steps to the frequencies where signals are expected for the given time-slot, and verifies the power balance of the several carriers being relayed by the satellite. It then scans the remaining spectrum for unauthorized users. If all data is within acceptable limits, no alarms are sounded. If, however, a given ground station is being relayed at too high or too low a power, or an unauthorized user is discovered, the system identifies the ground station involved and the nature of the violation. This information is displayed so corrective action may be taken.

The Automatic Stimulus/Response Tester

Use of automatic stimulus/response test systems has increased rapidly over the last five years. The minicomputer, with digitally programmable instrumentation, has made significant efficiency improvements in testing of many electronic components. The first of these systems was the static tester built around a digital voltmeter. Soon to follow were systems for stimulus/response testing of components operating from audio to ultra-high frequencies. Automatic microwave network analysis became an important extension of this capability. In all cases, the contribution of these systems was to

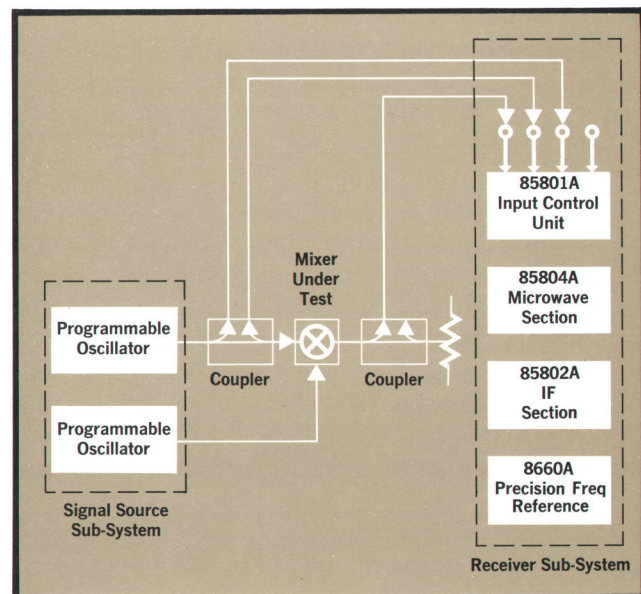

Fig. 4. Automatic Spectrum Analyzer is configured as test station for wideband mixers.

decrease overall testing cost by reducing test time and/or improving test accuracy.

The 8580A Automatic Spectrum Analyzer, when complemented with programmable signal sources and a programmable power meter for self calibration, adds to the capability of its predecessors by making measurements on *non-linear* and *signal-generating* components. It is well suited, for example, to test broadband microwave oscillators for output level, frequency accuracy, distortion, tuning linearity, and spurious outputs. It is also capable of evaluating near-linear devices, such as amplifiers, for distortion (harmonic, intermodulation, or cross modulation), as well as gain and return loss. Furthermore, components that translate frequency (mixers, modulators, multipliers) can be characterized on an ASA.

The signal sources available with the 8580A include the widely-used sweep oscillator as a programmable, fixed frequency source (0.1–18 GHz) and the new 8660A Synthesized Signal Generator³ as a high stability source (0.1–1300 MHz) that is also capable of both internal and external AM and FM.

The 432C Power Meter, with its associated thermistor mount, is also a standard extension of the 8580A. The 432C is a useful calibration standard to enhance the system's absolute level accuracy. Effectively, the accuracy of the power meter is transferred to the 8580A's receiver by measuring a stable, single-frequency signal with both, and generating an error correction factor for the receiver at each frequency of interest. This can be achieved completely automatically.

A representative application of the 8580A as a stimulus/response tester is as a mixer test station (Fig. 4). The critical parameters to be determined are input match, conversion loss, and unwanted signals at the IF port. To accomplish these tests, the 8580A will contain at least two sources—one to furnish the signal at the RF port of the mixer and the other to furnish the local oscillator signal. The measurement procedure entails characterizing the system flatness first, using the signal source and the 432C Power Meter. By measuring the signal with both the power meter and the receiver, calibration data is gathered and stored in the computer's memory. The next step is to insert the mixer under test and program both signal sources for the appropriate frequencies to simulate actual use of the mixer. Typically this means the local oscillator signal will remain offset by a fixed frequency from the signal applied to the RF port, producing a constant difference (IF) frequency. The 8580A can measure the IF

level, and knowing RF input level from the calibration run, can compute conversion loss. Other parameters of interest (match at RF port, local oscillator feedthrough, RF feedthrough, and unwanted mixing products) can be measured by the 8580A by retuning to a new frequency or by selecting another signal with the input control unit.

Acknowledgments

Ken Fox, working with Bill Ray, defined the basic structure of the command set; he implemented its first versions with Sue Slayen, and he participated in making the system's interpreter capable of economical field modification. Marge Dunckel did invaluable support work. 

References

- ¹Brian D. Unter, 'Fully Calibrated Frequency Domain Measurements,' Hewlett-Packard Journal, August 1968.
- ²Richard C. Keiter, 'A Fully Calibrated Solid State Microwave Spectrum Analyzer,' Hewlett-Packard Journal, September 1971.
- ³John C. Shanahan, 'Uniting Signal Generation and Signal Synthesis,' Hewlett-Packard Journal, December 1971.



Lynn M. Wheelwright (left)

After Lynn's formative years in Salt Lake City he went to Stanford for a year, then gave two years to his church as a missionary abroad. Returning, he went to Brigham Young University (Utah) and in 1970 took the B.E.S. (bachelor of electrical science) and M.S. there. Coming straight to HP then, he has been steadily on automatic microwave systems since.

Michael Cunningham (right)

Mike is a native San Franciscan; he grew up in the suburbs nearby, went to Stanford, and took a BS in EE, followed by an MS on the HP Honors program. His HP career began in 1962. He worked on pulse generators for the Colorado Springs Division, then on hybrid microcircuits for them and Microwave. He's been on the ASA since its inception. Mike and his wife have two children.

Organizing the Automatic Spectrum Analyzer System

Organization determines the usefulness of the system's many capabilities.

By William H. Shaffer

THE AUTOMATIC SPECTRUM ANALYZER has been organized with the intention of making it flexible in as many ways as possible, while fully exploiting its measuring capabilities.

The heart of the ASA system is a combination of plug-in elements from the HP manual spectrum analyzers. These are the two RF converters, the 0.1–110 MHz Model 8553B and the 0.01–18 GHz Model 8555A, with the IF Section, Model 8552B. In the manual analyzers they use an oscilloscope mainframe for display and power. In the ASA each fits into its own mainframe, which interfaces it to the controlling system with digital and analog circuits (Fig. 1).

The manner in which the microwave section is configured, with its entirely synthesized first local oscillator for precise control, is described in a following article. The IF section contains means to select discrete bandwidths, a logarithmic amplifier, an envelope detector, and an analog-to-digital converter. It also contains the power supply which is common to both of the RF converters. The use of the single supply helps reduce ground loops and thus helps to retain spectral purity in the LO's.

Party Line Control Bus

Control of the various RF and IF functions is performed via a party line system—a digital bus. Two fifty-conductor ribbon cables interconnect with all instruments. Each instrument is able to decode its own address, store incoming data and indicate valid or erroneous completion of operation. The operating system also expects functional reports from each instrument on the bus. These include an 'instrument o.k.' indication, which checks for disconnected external cables. There is an auto-

matic functional report on 'bus loading,' which checks for instruments either turned off or with power supply failures, and an 'error' report which indicates synchronous or asynchronous faulty operation. Using these error indicators the operating system then can flag or trap bad measurement data and initiate an appropriate response. If the system is being used in an interactive environment the operator can be notified by a message, for example. If the system is unattended, the operating system can try again, or tag the invalid data.

Self-Correction

Since it is much less costly to build electronic circuits with good repeatability than with extremely high precision, one might consider a method to account for errors: construct a model so errors can be taken into account at measurement time. Requirements for such circuits would be good temperature stability, known and stable offsets and gain errors, repeatable nonlinearities, and no hysteresis.

The RF converter and IF sections of the spectrum analyzer possess those qualities. Probably the most important source of amplitude inaccuracy derives from the fact that the temperature coefficient is not zero. However the thermal mass of the sensitive circuits is sufficiently large (something like an hour for a 10°C change) to require fairly infrequent updating of the system error model.

The sources of those amplitude inaccuracies that are present are input VSWR, mixer conversion loss, less-than-perfect frequency flatness, inaccuracy in the input RF attenuator, log/linear amplifier errors and nonlinearities in the analog-to-digital converter.

In the 8580A a calibration table is constructed which takes into account all amplitude-dependent

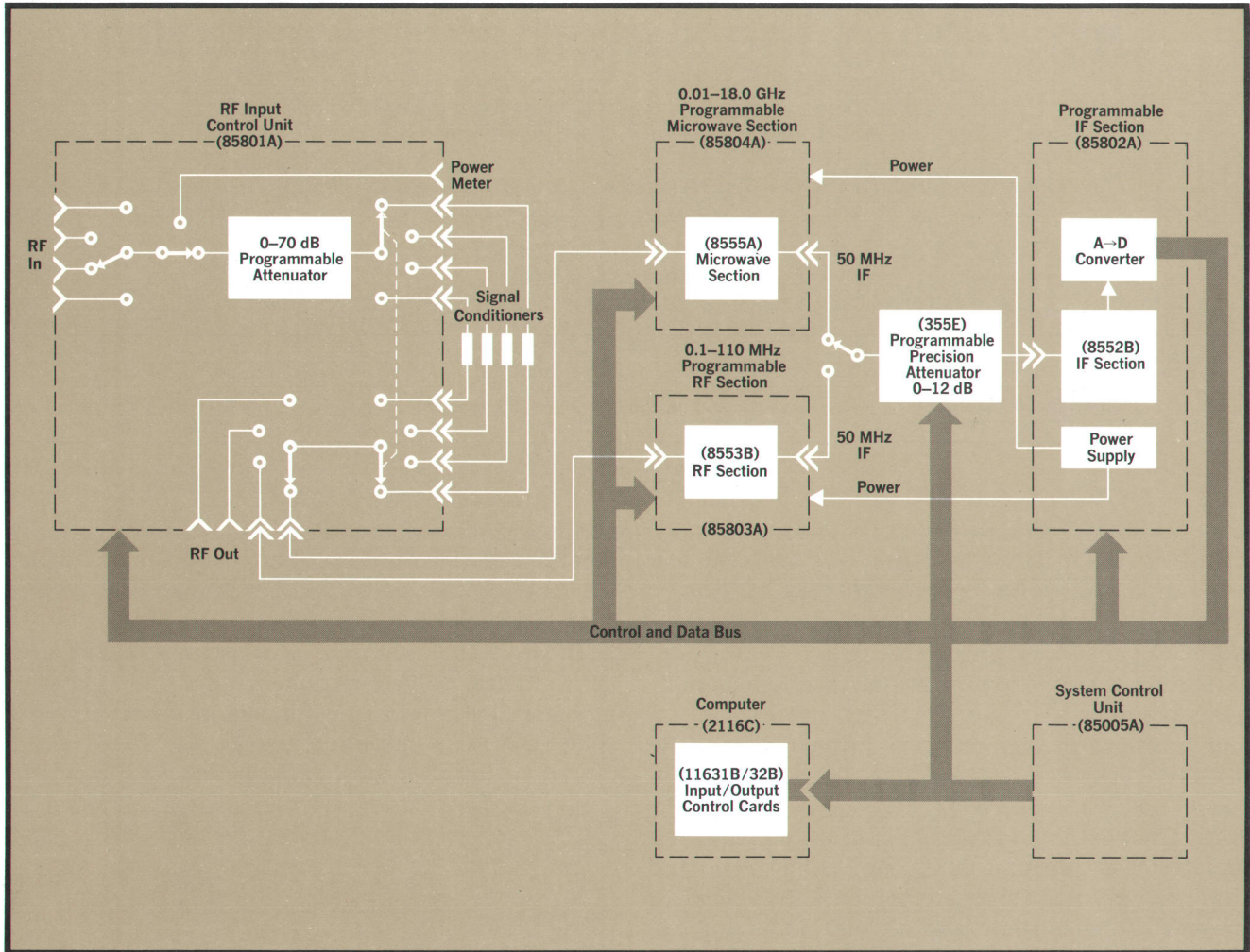

Fig. 1. Block diagram, Model 8580A Automatic Spectrum Analyzer.

variables at one frequency. This is then a relative amplitude calibration model, based on the accuracy and repeatability of a programmable step attenuator* inserted in the 50-MHz IF signal path between RF and IF sections (Fig. 1). When a measurement is made this table is consulted and the data corrected (Fig. 2).

A model of amplitude versus frequency can be constructed by comparing the analyzer's reading to a source of known amplitude, then computing and storing the errors. By combining the two models one can measure the absolute power of a signal at any frequency.

Timing

Timing of the system's operation is controlled both in the hardware and the software. Fixed hardware delays are associated with changing frequen-

* HP Model 355E, of twelve 1-dB steps, accuracy <0.02 dB, repeatability <0.005 dB at 50 MHz.

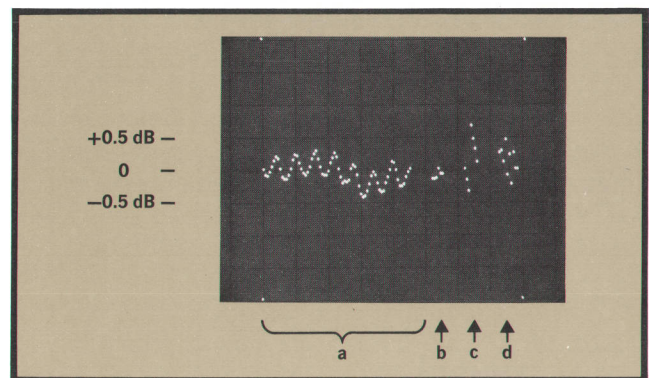

Fig. 2. Calibration error table. Error is shown on the vertical axis. Trace a is the error of a logarithmic amplifier, plotted from left to right across a 72-dB range. Trace b is the gain error in an IF amplifier, shown in steps of 10 dB each over a 50-dB range. Trace c is the error of the RF attenuator in 10-dB steps over 70 dB. Trace d is the insertion loss of an IF bandwidth filter at 10 different bandwidths ranging downwards from 300 kHz to 0.01 kHz in a 10-3-1 sequence.

10	RESET(-10,-130,2)			
20	PORTS(4,1,1)	t	72 ms	Change input ports Complete port change Output new data
30	TUNE(450)	t	3 ms	Tune analyzer to 450 MHz Computer time
40	ATTEN(30)	t	72 ms	Change RF Attenuator Complete change Computer time
50	BWDTH(0.3)	t		Select new bandwidth
60	FOR I=1 TO 10	t		Execute FOR loop Computer time
70	MEAS(X)	t	13.3 ms	Begin measurement Computer outputs new data word and sets ADC control Wait for bandwidth delay $4/BW = 4/0.3 = 13.3$ ms
			5 μ s	Sample and hold delay
			15 μ s	ADC Conversion
80	NEXT I	t		Go to t

Fig. 3. An 8580A program example (left) results in this typical timing sequence.

cy, IF gain, RF attenuation, band selection, signal conditioning, and input/output ports. Software delays are determined as a function of IF bandwidth and post-detection bandwidth (Fig. 3). The user normally never is concerned with these timing matters, since the individual instrument drivers handle them for him.

The Automatic Spectrum Analyzer can now be seen to have been organized so as to function as a *black box receiver*. Its design is such that it can be interfaced readily with other controlling systems. One such system is the Model 8500A Control and Display Console. This terminal adds the power of graphics to spectrum analysis, and adds much to the ability of the system in production and manufacturing applications. Details on the Control and Display Console will follow in a later issue of the Hewlett-Packard Journal.

Acknowledgments

I would like to acknowledge the many contributions of Bill Ray, who was the real guiding hand in the 8580 development. While handling the difficult job of project supervisor, he developed and implemented the digital bus, built the 85801A RF Input Control Unit, the 85810A Source Control Unit, and created the software programs to aid assembly and test of those instruments.

Fred Woodhull, Ken Astrof, Orrin Mahoney, and Yas Matsui all pitched in effectively throughout the project to help with many difficult phases of the development.

Bud Matthews had the task of repackaging the manual spectrum analyzer plug-ins, and along with providing some innovations for the digital bus he has designed a total of six new instrument mainframes. Hats off!

Sam Scott and John Hiatt must receive great credit for their contributions in guiding the project into production. 

SPECIFICATIONS

HP Model 8580A Automatic Spectrum Analyzer

FREQUENCY RANGE: 10 kHz–18 GHz
TUNING ACCURACY: ± 200 kHz, 0.01–110 MHz
 ± 2 kHz, 0.01–2.0 GHz
 ± 10 kHz, 2–18 GHz

FREQUENCY RESOLUTION:
 IF BANDWIDTHS: 0.01–300 kHz in 1,3 sequence
BANDWIDTH SELECTIVITY: $< 11:1$, 0.01–3 kHz
 $< 20:1$, 10–300 kHz

TUNING STABILITY:
 0.01–110 MHz 0.01–2 GHz 2–18 GHz
RESIDUAL FM:
 –50 dB @ ± 200 Hz –50 dB @ ± 75 Hz –50 dB @ ± 400 Hz
PHASE NOISE:
 –70 dB @ ± 50 kHz –70 dB @ ± 50 kHz –60 dB @ ± 250 kHz

MEASUREMENT RANGE: +30 to –90 dBm
AMPLITUDE RESOLUTION: 0.03 dB
RELATIVE AMPLITUDE ACCURACY: ± 0.1 dB, 0–20 dB
 (Signals at same frequency,
 reference level +10 dBm) ± 0.2 dB, 20–40 dB
 ± 0.4 dB, 40–60 dB
 ± 0.6 dB, 60–80 dB

PORTS: 8 input, 4 signal conditioning, 5 output
IMPEDANCE: 50 Ω , VSWR $< 2:1$
ISOLATION: 100 dB
PRICE IN U.S.A.: \$100,500.00; other versions from \$71,400.00
MANUFACTURING DIVISION: MICROWAVE DIVISION
 1501 Page Mill Road
 Palo Alto, CA 94304



William H. Shaffer

Bill Shaffer barely missed being a native Californian, coming to that State from Missouri when less than a year old. He grew up in the Santa Cruz region, went through high school there and in Sedona, Arizona, then took the BS in EE at the University of California at Santa Barbara, where HP recruited him. Bill finished an MS at Stanford in 1968. He's been working more than fulltime on automatic systems ever since, contributed to the design of the tracking filter in the HP Automatic Network Analyzer, and has been on the ASA program since mid-1969. Skiing gets him out of the lab now and then, water or snow as available.

Automating the 10-MHz-to-18-GHz Receiver

As it is automated, the spectrum analyzer not only acquires computer programmability but also some improvements in basic performance.

By Steven Neil Sanders

THE AUTOMATIC SPECTRUM ANALYZER can be viewed as a quadruple-conversion receiver of frequency range 0.01 to 18 GHz. Fig. 1 is its block diagram. At its heart are the elements of the basic, manually-controlled microwave spectrum analyzer, the HP Model 8555A Microwave Tuning Section, and the Model 8552B IF Section.¹ The major modifications to the Microwave Section are 1) synthesizing the first local oscillator, and 2) stabilizing the second and third local oscillators. These modifications do not change the local oscillator output powers, and thus many characteristics which distinguish this section are unchanged—absolute amplitude calibration, flatness of frequency response and intermodulation distortion remain the same.

Stability

Receiver frequency stability and accuracy, however, are enhanced. Long-term stability for microwave measurements is 3×10^{-8} /day and can optionally be made 3×10^{-9} /day. Frequency accuracy is now (using the optional crystal) 5 kHz at 18 GHz, frequency resolution 1 to 10 Hz, depending on the harmonic number. Fig. 2 illustrates the short-term stability and accuracy characteristics.

The Synthesized First Local Oscillator

The first LO consists of 7 phase lock loops (Fig. 3). The output of the comb reference loop is F_{comb} . A comb spectrum of this signal is generated in a sampler. The YIG oscillator is coarse-tuned to $H \cdot F_{\text{comb}} - F_{\text{offset}}$, and the upper loop locks at

$$F_{\text{YIG}} = H \cdot F_{\text{comb}} - F_{\text{offset}}$$

F_{offset} is derived from a portion of the associated frequency synthesizer (HP Model 8660A)² and covers a range of 9.999999 MHz in 1-Hz steps. $H \cdot F_{\text{comb}}$

covers a range of 2.05 GHz in 10-MHz steps by varying F_{comb} and H . (H can take on integer values from 11 to 22 while F_{comb} can be one of 169 frequencies between 177 and 196 MHz.) The net result is that F_{YIG} can cover an octave range from 2.05 to 4.10 GHz in 1-Hz steps. That is a frequency resolution of 1 part in 2.05 billion!

The frequency accuracy and long-term stability of the first LO depend entirely on the crystal oscillator used. It can be an external standard of 1, 5, or 10 MHz. In such a case the stability of the first LO may be further enhanced, since it will be determined by that of the external standard.

The Propitious Trade-offs

Why use this synthesized oscillator scheme? It turns out that the conflicts are reduced, in this way, among some seemingly opposed desirables.

When looking at phase noise (single-sideband phase noise) we consider only that within the bandwidth of the upper loop. There are two major contributors. One is the phase noise of F_{offset} , which adds directly. The second is the phase noise of F_{comb} , which is multiplied by H and may amount to raising it 21 to 27 dB. Therefore F_{comb} must be a much cleaner carrier than F_{offset} .

Here, then, lies the reason for the scheme: F_{offset} is inherently noisier than F_{comb} because F_{offset} carries with it high frequency resolution and also the complication of five phase lock loops; F_{comb} is a single phase lock loop covering only a small percentage of an octave.

Achieving desirable spurious-response and tuning-speed characteristics also led to this choice. The result is a first LO with 1-Hz resolution and phase noise 30 kHz from the carrier typically only about 5 dB worse than that of the manual spectrum analyzer. That figure is still within the performance

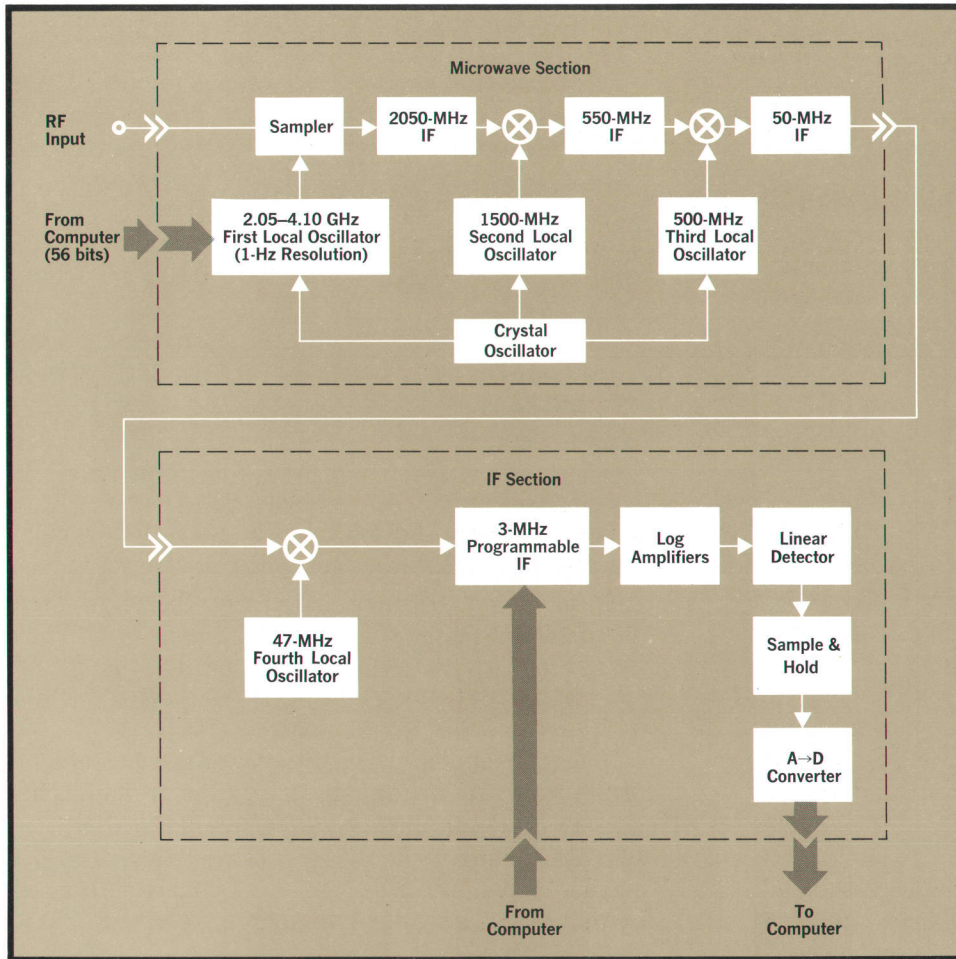

Fig. 1. Block diagram of the microwave receiver of the HP Model 8580A Automatic Spectrum Analyzer system.

specified for the manual analyzer (Fig. 4). All this, it may be noted, has nothing to do with noise figure. There are, of course, limitations on tuning speed.

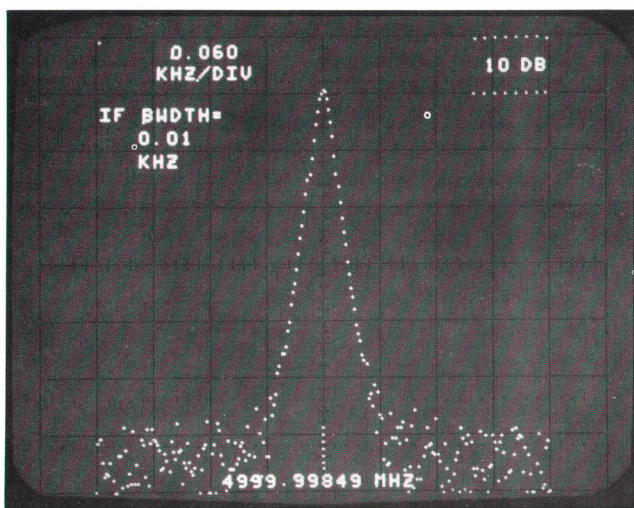

Fig. 2. The ASA measures a 5-GHz signal (well, 4.99999849 GHz) at 60-Hz/div horizontal scale, 10 dB/div vertical. The signal is a 5-MHz crystal multiplied 1000 times.

When a phase lock loop changes frequency there is, after lock, a phase transient $[\phi(t)]$ which dies out exponentially with time. Frequency does not assume its steady-state value until $\phi(t)$ is constant, since $\Delta F = d\phi(t)/dt$, where ΔF is frequency deviation from the steady state. The phase transient of F_{offset} adds directly to that of F_{YIG} , while the phase transient of F_{comb} is multiplied by H before being summed with the transient of F_{YIG} . This means F_{comb} should be designed so as to settle to the right frequency H -times faster than F_{offset} . Yet at the same time, the phase noise of F_{comb} is H times more critical.

Maximizing switching speed and minimizing phase noise on F_{comb} appear to be conflicting requirements. Fast switching speed implies maximum loop bandwidth, but there is only one unique bandwidth which will produce minimum phase noise on the LO.³ This value is typically much less than the maximum possible bandwidth because crystal oscillators are characteristically clean close to their carrier, while voltage-controlled oscillators tend to be cleaner further out.

It is possible to achieve both of these desirable

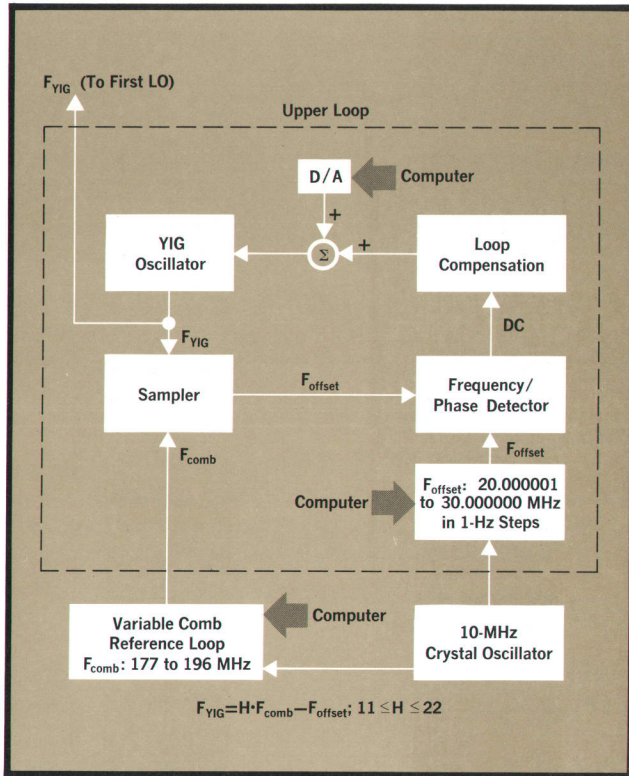

Fig. 3. Block diagram of the first local oscillator. $F_{VIG} = H \cdot F_{comb} - F_{offset}$; $11 \leq H \leq 22$. F_{VIG} is coarse-tuned to harmonic H by the computer.

characteristics if a phase lock loop of *adaptive bandwidth* is used.

The Adaptive Bandwidth Phase Lock Loop

An adaptive bandwidth phase lock loop will accomplish two things: 1) it will reduce the time required to slew a voltage-tuned oscillator (VTO) to a new frequency, and 2) once it is phase locked the adaptive bandwidth loop will reduce the phase transient to its steady-state value much more quickly than a conventional loop. There is surely little benefit in quickly moving an oscillator close to lock, then allowing a long phase transient to follow. The adaptive bandwidth approach greatly reduces the time needed to settle at the proper frequency. It also eliminates the need for clumsy pre-tuning and those test-time-hungry shaping networks which are found in more conventional phase lock loops where speed is important. Pre-tuning is unnecessary so long as a frequency/phase detector can discriminate properly during worst-case frequency changes.

The design criteria now are 1) to optimize the internal phase noise characteristics of the VTO (VTO tuning linearity is only secondarily important), and 2) to optimize loop bandwidth so as to produce the cleanest possible local oscillator (not

fastest response). The adaptive bandwidth loop gives the fast speed.

The adaptive bandwidth loop is shown in Fig. 5. A simple phase lock loop using a digital frequency phase detector is inside the shaded area of the figure. Speed of lock and phase settling are determined by the state of the system at $(t=0)$ and the loop bandwidth. If the ENABLE line and $K(t)$ (an amplifier that changes gain with time) are added, then an adaptive bandwidth loop results. It will slew the VTO $(K_{max} + 1)$ —about 250—times faster than before, which eliminates the need to pre-tune the VTO. The loop locks at time t_1 ($100 \mu s$ max) and the phase lock loop now works as a control system, as the frequency/phase detector enters its phase-detector mode. Because $K(t_1) = K_{max}$, the bandwidth of this now-active control system is $[1 + (K_1/K_2)K_{max}]$ times greater than when $K(t) = 0$. The increased bandwidth reduces the phase transient much faster than in the simple phase lock loop case. As the transient dies out the bandwidth also reduces until $K(t \geq t_2) = 0$. The bandwidth now is optimum for noise considerations. Large FM sidebands exist on the output until time t_2 , making the output useless, but nonetheless at time t_2 this loop is much closer to the right frequency than with a conventional loop having coarse tuning and a shaped VTO.

Fig. 6 shows four signals which occur as the loop is commanded to make a worst-case frequency change, about 18 MHz. V_{enable} and $K(t)$ are self-explanatory. $F(t)$ is the frequency transient, which shows the output frequency is within 10 Hz after 2 ms! The bottom trace shows the output mixed

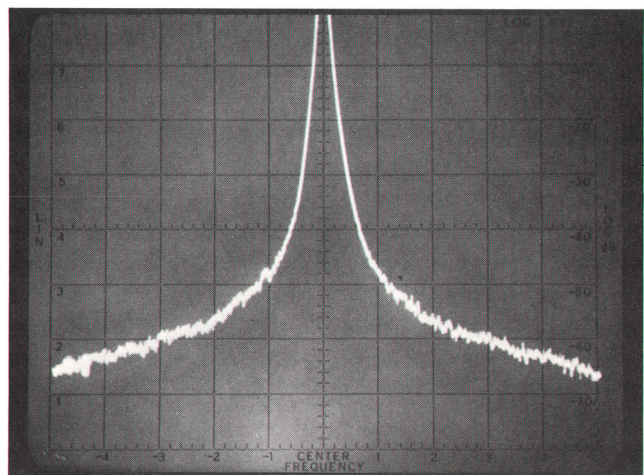

Fig. 4. Spectrum of the first local oscillator. Scale is 10 kHz/div horizontally, 10 dB/div vertically. IF bandwidth is 1 kHz. A 10-Hz video filter is in use. The signal level is 10 dB above the log reference (uppermost line).

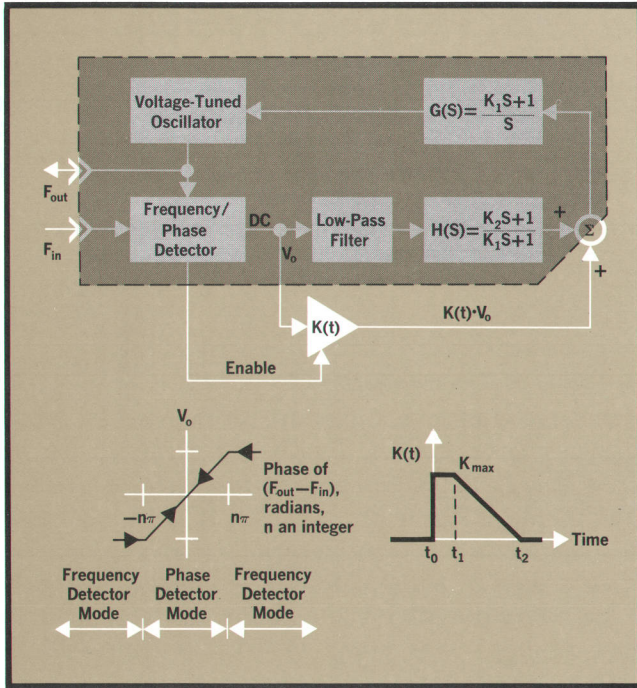

Fig. 5. Adaptive bandwidth phase lock loop. $V_{enable} = 0$ if $|f_{out} - f_{in}| < \epsilon$. $V_{enable} = 1$ if $|f_{out} - f_{in}| > \epsilon$, and ϵ is small compared to the capture range of the loop. t_0 : loop is commanded to change frequency. t_1 : loop locks (100 μ s or less). t_2 : bandwidth is reduced to normal (500 μ s or less).

with another oscillator at the upper frequency limit, about 196 MHz. These characteristics would not change appreciably for a smaller frequency step, except that t_1 is proportional to the step size.

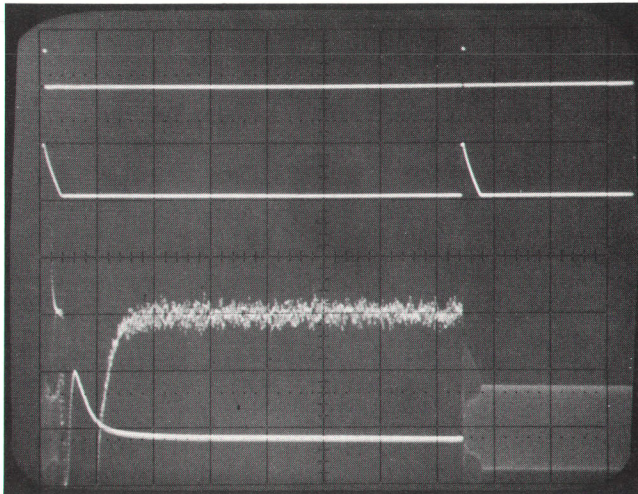



Fig. 6. Worst-case frequency change characteristics. Upper trace is V_{enable} . 2nd trace is $K(t)$. 3rd trace is $F(t)$ at 100 Hz/div, showing that output frequency is within 10 Hz after only 2 ms (1 ms/div horizontal scale). Lowest trace is phase transient, change thus about 1 radian/div near center of trace. Loop bandwidth is 10 kHz.

Conclusion

In these several ways the receiver section of the Automatic Spectrum Analyzer has been designed so as to address itself to widely varying uses—those which demand fastest tuning speed, those which need maximum stability and accuracy, and those which call for minimal noise—with least mutual compromise.

Acknowledgment

The synthesizing scheme described here originated with Jim Thomason. Herb Pardula came into the project in midstream and under great schedule pressure he successfully completed the auto/manual control aspects of the receiver. We owe the 8660A team thanks for their endless patience in interfacing their synthesizer to our needs, and our 85814A plug-in to their instrument. Our debt to the 8555A group is similar, for anticipating many of our needs. 

References

1. Richard C. Keiter, 'A Fully Calibrated, Solid State Microwave Spectrum Analyzer,' et seq, Hewlett-Packard Journal, September, 1971.
2. John C. Shanahan, 'Uniting Signal Generation and Signal Synthesis,' Hewlett-Packard Journal, December, 1971.
3. Douglas K. Rytting and Steven N. Sanders, 'A System for Automatic Network Analysis,' Hewlett-Packard Journal, February, 1970.

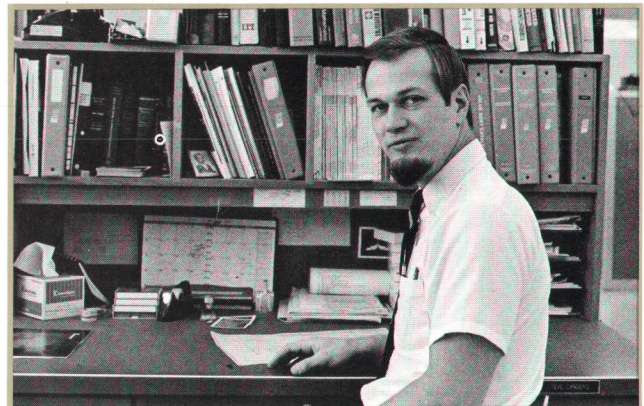

Steven Neil Sanders

Steve Sanders was recruited to HP from Utah State as he took his BSEE there in 1967. Steadily associated with automatic systems ever since, he was responsible for a new vector detector which greatly enhanced the precision of the HP Automatic Network Analyzers before joining the ASA program. Steve found time, yet, to take a Master's in EE at Stanford under the HP Honors Program, to marry and found a family, and more recently to kayak not only down many of Northern California's wild rivers, but also the Salmon in Idaho.

Hewlett-Packard's Barney Oliver and John Cage Write the Book

No one or two authorities on instrumentation could alone have produced the new McGraw-Hill text "Electronic Measurements and Instrumentation" which Oliver and Cage have edited.

THIRTY-FIVE AUTHORS from seven different institutions, and two distinguished editors, have produced a new text on electronic instrumentation—one which at last does justice to the art, at this period in its state of development. Aimed at graduate students in EE, it will give practicing engineers and physicists a thoroughly updated understanding of the most modern instruments and measurement techniques in research, development, and testing. It could also give technical managers new insights, the better to understand what is really happening in the experimental work directed.

In the opening, HP R & D vice president Oliver first establishes instrumentation's firm foundation on basic principles. As early as page 65 the excitement of some most-recent understandings emerges as Gordon Roberts (engineering manager at HP Ltd., Scotland) explains measurements "of, with, and in the presence of noise." As Cage notes in his preface, "without an understanding of this material, how can an engineer or scientist penetrate very far in any discipline involving variable quantities?" Equally consequential is the chapter by Ron Potter (HP Santa Clara Division) on signal analysis by digital techniques.

One is tempted to go on chapter after chapter. The section on microwave measurement, for example, shows how far this art has progressed beyond point-by-point slotted line tests. Many readers, even of recent advanced education, may find here that they never before really comprehended spectrum analysis.

The best review, though, is a sample of the content. Following, with McGraw-Hill's kind permission, is Dr. Oliver's learned, witty, profound, and provocative introductory discussion of the role of measurement. What he says here has special relevance to those who rely on HP's products and services, because in stating the role of measurement he is eloquently stating the mission of the Hewlett-Packard Company.

The Editor

The Role of Measurement

Science and technology are so intertwined with measurement as to be totally inseparable from it. It is true that modern measuring instruments are one of the fruits of science, but it is equally true that *without the ability to measure, there would be no science*. When Lord Kelvin warned that knowledge not expressible in numbers was 'of a meager and unsatisfactory kind,' he was not expressing a fetish; he was identifying an essential aspect of scientific knowledge. The laws of physics are quantitative laws, and their validity can only be established by precise measurement. It is the insistence on quantitative agreement of theory with experimental fact that distinguishes science from philosophy.

The careful astronomical observations of Tycho Brahe and the brilliant analysis of his data by Johannes Kepler illustrate very dramatically the contribution of accurate measurement to scientific progress. Plato, and the Greek philosophers who followed him, believed that the heavenly bodies, being perfect, were composed of the quintessence (literally the fifth essence of matter as distinct from earth, fire, air, and water) and that their motions must be eternal and perfect. Certainly the stars moved in circles, and it was believed that the motions of the planets could be described by an appropriate combination of uniform circular motions. For two thousand years the resolution of planetary motions into circular components was considered the most important problem in astronomy. The heliocentric theory of Aristarchus of Samos (250 B.C.), the geocentric theory of Ptolemy (A.D. 150), and even the heliocentric theory of Copernicus (A.D. 1543), all adhered to the concept of circular motions. But even though the Copernican theory greatly simplified the Ptolemaic theory by eliminating the large epicycles that were really the result of the earth's own motion, neither theory predicted the exact positions of the planets at all times. The error in both theories was often as much as two degrees.

To Tycho Brahe, who was born shortly after Copernicus' death, two degrees of error was intolerable. He decided that, before any correct theory could be discovered, the actual positions of the planets over many years would have to be measured with far greater accuracy than ever before. With the financial support of Frederick II of Denmark he built very large and rigid quadrants and other instruments for measuring angles. These he mounted on stable foundations in his observatory, which he named Uraniborg, or 'castle of the heavens.' Then he *calibrated* his instruments so that he could subtract their errors from his observations. For twenty years he recorded the positions of the planets. After the death of Frederick II he moved to Prague, where Kepler became his assistant.

Kepler was assigned the task of computing the orbit of Mars from Brahe's observations. After four years of arduous work Kepler came to a painful conclusion. No combination of the deferents and epicycles of the Copernican or the Ptolemaic systems would fit the facts. The motion of Mars could not be compounded out of regular circular motions as Plato had believed. The best solution Kepler found disagreed with observations by only eight minutes of arc. But Kepler knew that Tycho Brahe's observations could not be in error by more than two minutes of arc. With an integrity rare even in scientists, Kepler saw that beliefs twenty centuries old were doomed by an error only six minutes of arc too big to be allowable.

Kepler then went on to discover his famous laws of planetary motion. Eighty years later Newton showed that all these laws were a consequence of his own laws of motion and his theory of universal gravitation, and thus provided convincing proof of the latter. Shattered forever were the crystalline spheres that carried the planets in their Ptolemaic orbits. All the complex motions of the planets, which had puzzled men for ages, were distilled into one simple little equation.

Nor does the story end here, for later and much more accurate observations, with telescopes, showed that the orbit of Mercury precessed by 43 seconds of arc per century more than could be accounted for by perturbations of the other planets. This in turn later provided the best confirmation we yet have of Einstein's general theory of relativity, which subsumes Newton's law of gravitation as a special case.

The role of measurement in unraveling the mysteries of celestial mechanics is paralleled in other branches of science. Quantitative measurements of the stoichiometry of chemical reactions established

the existence of the atom, and precise measurements in spectroscopy have helped reveal its structure. Today, measurements of the trajectories of nuclear fragments are gradually revealing the nature of the nucleus. X-ray diffraction studies have taught us how crystals are built and have provided important clues to the nature of deoxyribonucleic acid (DNA) and other organic molecules. The list is endless, for after Tycho Brahe, Galileo, and Newton, science became experimental, and all experiments involve measurement. Man finally learned not to impose his beliefs on nature but, instead, humbly to ask questions of her and apply reason to her answers.

New discoveries in science provided new instruments for the study of nature and these studies produced new discoveries in a regenerative buildup that has been accelerating for the last two centuries and continues to accelerate today. Though much of physics has now been explored, many mysteries still remain at both extremes of size: the nucleus and the cosmos. The fields of particle physics and cosmology together with molecular biology are the major frontiers of modern science. All depend heavily upon instrumentation and measurement.

The science of optics produced the first major contributions to scientific instrumentation: the telescope, the microscope, and the spectroscope. When Galileo refined Fleming's spyglass and turned it toward the heavens, a new era in astronomy was born. Later the spectroscope not only revealed new elements on earth, but provided the final, uncontrovertible proof that the stars themselves, like our sun, are composed of these same elements. The microscope showed the cellular structure of living matter and the microorganisms that are the cause of disease.

Imagine how different human history might have been had Aristarchus of Samos had a telescope and spectroscope, and Hippocrates a microscope! What Greek could have believed in the quintessence of matter having seen the mountains of the moon and spectral lines of earthly elements in sunlight? Or who could have insisted that all heavenly bodies revolved around the earth, having beheld the satellites of Jupiter? How could the deity have been so wasteful as to adorn the sky with stars not even visible to man's naked eye? What need for evil spirits if microbes cause disease? The impact of such discoveries, had they been made by the Greeks, would surely have greatly accelerated civilization and profoundly affected theology. Indeed the western world might have been spared the dark ages and the tortures of the Inquisition if only the Greeks had

had better instrumentation.

In recent years both astronomy and biology have taken new leaps forward, again because of new tools, this time the result of progress in electronics. The radio telescope has enabled astronomers to study the matter between the stars in what was once thought of as simply space. Quasars, perhaps the most distant objects in the universe, and pulsars, believed to be star corpses composed almost entirely of neutrons, have been discovered with radio telescopes. Meanwhile, the electron microscope has revealed single strands of DNA and many of the fantastic transfer mechanisms in the living cell that use the genetic code to construct proteins, antibodies, and enzymes. Living things too, it now seems certain, obey the laws of physics and chemistry.

The role of science is to discover the laws of nature and how they operate in complex systems. The role of engineering is to apply the discoveries of science to human needs. Scientists make discoveries that increase our understanding of the world. Engineers make inventions intended to increase our productivity (and thereby our standard of living), our mobility, and (it is hoped) our ability to survive. Instrumentation is a branch of engineering that serves not only science but all branches of engineering and medicine as well.

The precise measurement of dimensions, temperature, pressures, power, voltage, current, impedance, various properties of materials, and a host of other physical variables is as important to engineering as to science. Thus, mass production of goods that has produced our present affluent society would be impossible unless their parts could be made so nearly alike as to be completely interchangeable.

Eli Whitney, the inventor of the cotton gin, seems to be the first to have eliminated the need for selective assembly. In 1798 he obtained the contract to produce ten thousand muskets for the United States government and decided 'to substitute correct and effective operations of machinery for that skill of an artist which is acquired only by long practice and experience.' It took Whitney two years, during which time not a single gun was produced, to develop the machines, tools, and fixtures to do the job. Washington officials became nervous at the delay, but finally Whitney appeared before the Secretary of War and other Army officers with boxes containing all the parts of his musket. While they watched in amazement, Whitney assembled ten muskets, taking parts indiscriminately from the boxes. Afterwards, in a letter to Monroe, Jefferson

wrote: 'He (Whitney) has invented molds and machines for making all the pieces of his locks as exactly equal, that take a hundred locks to pieces and mingle their parts and the hundred locks may be put together by taking the pieces that come to hand.'

Accurate measurement is needed too for economy of design. A bridge several times stronger than needed to carry its heaviest possible load serves no one better and costs more than one designed to survive this worst load safely. For millions watching television, the most dramatic moment of the Apollo 11 mission occurred when Neil Armstrong first set foot on the moon. But for many of the engineers who designed the vehicles and the computer programs, the most dramatic moment occurred two hours earlier when the lunar landing module set its feet on the moon. At that moment, only ten seconds worth of fuel remained. Close timing indeed, and a tribute to the designers of the mission, for every pound of spare fuel that did not have to be allowed for in the landing module could be used to increase the payload of the lunar escape module.

Not only are instrumentation and measurement playing an increasingly important role in our technological society; electronics is playing an increasingly important role in instrumentation. The reasons for the latter are that most physical quantities can be converted by transducers into electrical signals and, once in this common form, they may be amplified, filtered, multiplexed, sampled, and measured. The measurements are easily obtained in or converted into digital form for automatic analysis and recording, or the data can be fed to servo systems for automatic process control. Electronic circuits are unexcelled in their ability to detect and amplify weak signals and in their ability to measure events of short duration. The incorporation of electronic sensors and circuits into instruments has vastly increased our ability to measure and thereby our ability to find nature's answer to new questions.

Where science will take us in the future, no one knows. That is what makes it such an exciting adventure. But one thing seems certain. If social or political or ecological catastrophe can be avoided, science will continue to probe with new and even more sensitive instruments while the riddles of matter, of the origin of the universe, and of life are being answered. Perhaps in time we may be able to construct a philosophy in total accord with all knowledge. Or perhaps, as is more likely, we shall no longer feel the need for philosophy. For what is philosophy but intellectual speculation turned into belief, and what place is there for speculation except to develop premises to be tested? 

Fine-line Thermal Recording on Z-fold Paper

By Walter R. McGrath and Arthur Miller

USERS OF STRIP-CHART RECORDERS are finding definite advantages to paper that folds rather than rolls. For one, it is much easier to look for events or phenomena in particular sections by thumbing through a folded record which, incidentally, has numbered pages, than it is to unroll and reroll a long chart (Fig. 1). For another, a record folded up in a neat, rectangular package is much easier to store and ship than a roll.

Consequently, accordion-folded recording paper, or Z-fold paper as it is generally known, is becoming more and more popular for analog recording. But Z-fold paper has not been very successful with traditional thermal recorders because the trace tends to blur when the stylus passes over the folds of the paper.

If it were not for the high contrast, easy-to-read traces and dependability of thermal recorders, their poor performance with Z-fold paper might well have made them obsolete. But thermal recorders also have other desirable features—they can be depended upon to write consistently and there is never a start-up problem, even after long periods of inactivity. Furthermore, since there is no fluid to run out of, thermal recorders are ideally suited for long-term, unattended recording.

Conventional thermal recorders draw the paper between a knife-edge platen and a heated stylus, a short, metal ribbon mounted on the galvanometer arm. The ribbon melts the opaque wax layer, exposing the black paper beneath as a line. Since the metal ribbon touches the paper only where it passes over the knife-edge platen, the curved motion of the galvanometer arm is converted into a straight-line motion.

Z-fold paper is roughened slightly where the paper folds, so more of it comes in contact with the stylus ribbon where the fold passes over the knife edge. This blurs the trace, leading to the possibility of a loss of important detail.

Hence a new thermal recorder, one that uses a hot-tip stylus to write on a flat surface. The hot tip does not broaden the trace where the paper folds,

making Z-fold paper compatible with thermal writing. The hot-tip stylus writes a sharp, high contrast trace in all parts of the recording.

The new Recorder (Hewlett-Packard Model 7414A/7754A) has other advantages, gained as a result of a new galvanometer design. Position feedback eliminates the hysteresis that has been characteristic of thermal-writing galvanometers—even the best of them would smooth over small signal variations corresponding to trace movements less than 0.2 mm. The hysteresis results primarily from friction between stylus and paper. Position feedback (see box) reduces this to imperceptible levels and with frictional hysteresis no longer a problem, higher stylus pressure can be used, improving the quality of the trace.

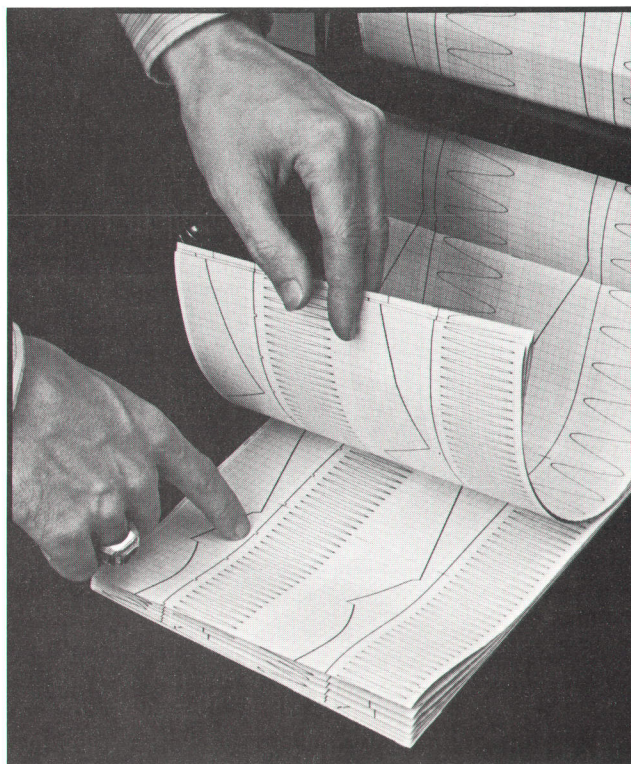

Fig. 1. Z-fold makes it easy to search through a long recording, even while the recording is being made.

Rectilinear recording is obtained by use of a double linkage that converts the rotary motion of the galvanometer motor to linear motion at the tip (Fig. 2).

Heating a Tip

The primary problem to be dealt with in designing the hot-tip stylus was elimination of thermal lag. Heat is lost from the tip by conduction to the paper and platen, and it is lost by convection as movement of the galvanometer fans the stylus through the air. To maintain sufficient temperature levels, heat must be conducted to the tip quickly.

This problem was solved by using a tiny heating coil around the stylus shank, placed as close as practical to the tip (Fig. 3), and using beryllium

oxide for the stylus material. Beryllium oxide was selected after much experimentation with various metals. It has a thermal conductivity as high as that of pure aluminum at room temperature, rising to 150 BTU/hr/ft²/°F/ft at 1800°F. Yet it is an excellent electrical insulator, eliminating any danger of short circuits from accidental contact with the heating coil. It has low thermal expansion and extremely good wear characteristics, its hardness being 1220 on the Knoop scale and approaching that of tungsten carbide (1880).

The 0.002" Nichrome wire heating coil, insulated with glass fiber, is wound 7 turns to a layer. The coil's center provides a close sliding fit to the stylus shank and after assembly, the coil's temperature is raised briefly to a level that fuses the glass

Position Feedback for Galvanometer Fidelity

A variable-capacitance transducer gives galvanometer position information to the feedback network in the driver amplifier of the new Model 7414A/7754A Recorder to improve fidelity. Operation of the system is diagrammed in the drawing below.

A 200-kHz signal is coupled to the transducer's stator by the capacitance between the transducer's upper plate and the stator. The amount of coupling to each plate is determined by the position of the rotor, a conductive shield that reduces the effective area of the signal-coupling capacitance as it intrudes between the stator and upper plate.

At the zero position of the galvanometer, equal amounts of signal are coupled to the two pairs of stator plates. The coupled signals are rectified by the diode-transistor pairs, D1-Q1 and D2-Q2. Because these are connected in opposite polarities, the two rectified dc currents cancel each other and there is no net current delivered as negative feedback through R2 to the summing junction at the amplifier input.

When the galvanometer rotates, however, one pair of plates

gets more signal and the other less. The current through R2 then has a magnitude proportional to the angle through which the galvanometer has rotated and a polarity determined by the direction of rotation. Ripple components are filtered by capacitor C.

Note that the rotor does not function as a capacitor plate but simply serves as a shield. The system is thus relatively insensitive to longitudinal movements of the galvanometer shaft, as compared to systems that use the rotor as a capacitor plate. By easing requirements on end-play tolerances, this reduces the cost of manufacture. Furthermore, there is no need for slip rings or other devices for connecting a signal to the rotor.

Another advantage of this system is that the rotor plates can be shaped to make the transducer transfer function follow any desired mathematical law. For the galvanometer linkage used in the new 7414A/7754A Recorder, a sine-law response obtains exact proportionality between the feedback current and stylus tip deflection.

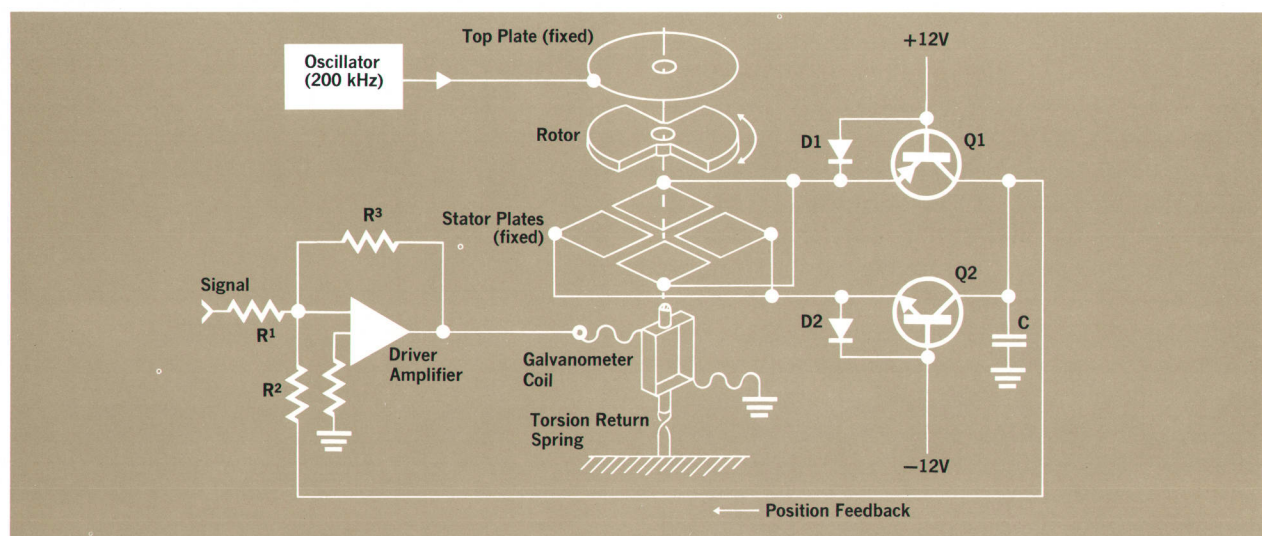

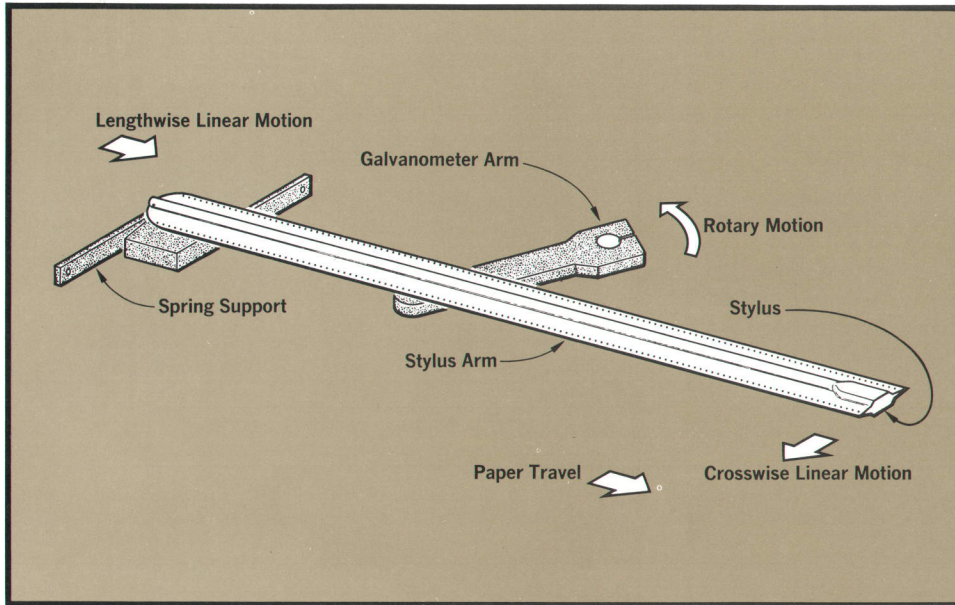

Fig. 2(a). Rotary motion in the new Recorder's galvanometers is converted to linear motion by the linkage shown in the drawing. The galvanometer arm moves the stylus arm sideways in accordance with the input signal. The stylus arm is restrained at the rear by leaf springs that permit forward and backward motion but no sideways motion. The resulting lengthwise motion of the stylus at the rear straightens the crosswise motion of the stylus at the front, moving the stylus within 0.125 mm of a straight line over the 40 mm full-scale stylus travel.



Fig. 2(b). Multiple exposure photo shows straight-line motion at galvanometer tip. (Device at center is relay operated event marker.)

insulation, locking the coil and stylus together rigidly. The tip is lapped and its shape is rectangular (0.010 x 0.020 inch), giving a more durable contact than a point would.

In a test for ruggedness, a galvanometer equipped with the new stylus was driven by a sine wave of

sufficient amplitude to produce full-scale deflection, swept from a low frequency to 60 Hz every 5 minutes for 500 hours, with no measurable wear at the tip. In another test, a galvanometer was driven 7 hours with a full-scale 30Hz sine wave while the tip was sliding on the bare metal platen. Again, writing quality was unaffected. Coils have been exposed to the atmosphere at a temperature of 1600°F for 160 hours without damage or writing impairment.

The new stylus has made it possible to obtain a marked improvement in the clarity of thermal writing with greater dependability and with the convenience of Z-fold paper. 

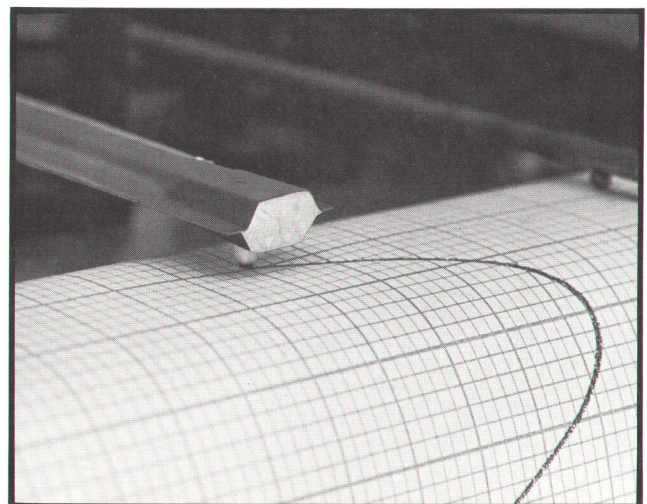

Fig. 3. Heating coil and stylus are fused into monolithic structure with short heat path. Stylus tip contacts paper in 0.010 x 0.020 inch area.

New Recorders Use Hot-tip Writing

The first Hewlett-Packard Recorder to use the new hot-tip galvanometer is the Model 7754A, a four-channel instrument intended for physiological recording in the operating room, shock unit, pulmonary function lab, or at bedside. A similar Recorder, Model 7414A, is intended for industrial applications.

These Recorders use the well-proved 8800-series plug-in signal conditioners, now numbering 12. These include dc amplifiers with sensitivities to $1\mu\text{V}/\text{div}$, carrier amplifiers with gains of $\times 10,000$, bioelectric amplifiers, pressure processors, heart or respiration rate computers, and others. The galvanometers respond within 5 ms to a 20 div signal transition. Frequency response goes from dc to 50 Hz with 50-div full-scale deflection, increasing to 100 Hz for 10-div deflection (50 div = 40 mm). Chart speeds range from 0.25 to 100 mm per second.

In addition to four galvanometers, the new Recorders also have two event markers, one that makes either 1-second or 1-minute timing marks, and one that marks the occurrence of special events in response to either a front-panel push-button or a remote electrical signal.

Chart paper comes in lengths of 496 feet (152.5 meters), folded into a pack of 500 sheets. Each sheet is 11.9 inches (30.1 cm) long and 7.8 inches (16.8 cm) wide.

The Recorders measure 19 x 10.5 x 23 inches (48 x 29 x 57 cm), small enough to sit on a lab bench (covers add about 1½ inches to all dimensions). They can also be fitted to a mobile cart, as shown below, or mounted in an instrument rack.

The Recorders cost \$4500 each without signal conditioners, which range from \$125 to \$700. Chart paper is \$25 per pack of 500 sheets.

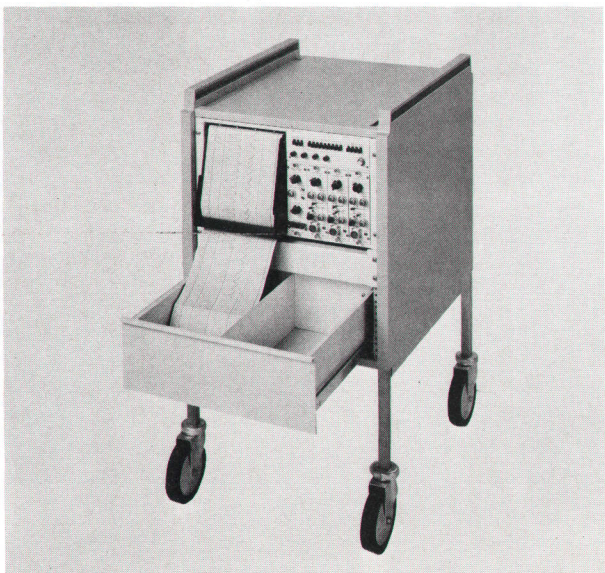

Walter McGrath, Jr. (left)

Walter McGrath first came to work for the Sanborn Company, now HP's Medical Electronics Division, as a co-op student in 1954. He joined the company full-time after earning his BSME degree from Northeastern University in 1957.

At Sanborn/HP, Walter has worked on many recorders, most recently the Model 7825A Trend Recorder, the 7826A central-station ECG Recorder, and now the 7414A/7754A 4-channel Thermal Recorder.

Outside of working hours, Walter has devoted a considerable amount of time during the past six years to a youth hockey program that now involves some 120 boys.

Arthur Miller (right)

Hewlett-Packard didn't even exist at the time that Arthur 'Doc' Miller joined the Sanborn Company in 1936. Doc went right to work developing the amplifiers for the first Sanborn vacuum-tube electrocardiographs. Previously he had operated his own radio repair service while attending high school and college. He earned his BSEE degree in 1934 and ScD degree in 1938, both from MIT.

During the early days of WWII, Dr. Miller served as a consultant to the National Defense Research Committee but later returned to Sanborn to carry on defense-related activities going on there. Following the war, he developed both galvanometer and amplifiers for Sanborn's first direct-writing electrocardiograph. He then adapted these techniques to scientific and industrial recording applications.

Dr. Miller was made Sanborn's Acting Director of Engineering in 1957 and Director of Research a year later. In 1964, the HP Board of Directors appointed him Senior Staff Engineer, an honorary appointment conferred on those who have made outstanding contributions to the company's technological progress. Doc officially retired in 1969 but continues actively as a consultant to the company while devoting much time to several national and international committees working on guidelines for safety in patient instrumentation.

HEWLETT-PACKARD JOURNAL



FEBRUARY 1972 Volume 23 • Number 6

Technical Information from the Laboratories of Hewlett-Packard Company, 1501 Page Mill Road, Palo Alto, California 94304 U.S.A.
Hewlett-Packard S.A. 1217 Meyrin—Geneva, Switzerland • Yokogawa-Hewlett-Packard Ltd., Shibuya-Ku, Tokyo 151 Japan

Editor: R. H. Snyder Editorial Staff: R. P. Dolan, H. L. Roberts, L. D. Shergalis Art Director: Arvid A. Danielson Assistant: Erica R. Helstrom